

Generalized monotonicity from global minimization in fourth-order ordinary differential equations

Mark A Peletier

Centrum voor Wiskunde en Informatica, PO Box 94079, 1090 GB Amsterdam, The Netherlands

Received 26 September 2000, in final form 3 May 2001

Published 6 August 2001

Online at stacks.iop.org/Non/14/1221

Recommended by F Otto

Abstract

We consider solutions of the stationary extended Fisher–Kolmogorov equation, with general potential, that are global minimizers of an associated variational problem. We present results that relate the global minimization property to a generalized concept of monotonicity of the solutions. This monotonicity can be described as the lack of intersections of the solution curve when projected onto the (u, u') -plane.

Our method is based on applying a cut-and-paste argument in the space $*H^2(\mathbb{R})$ to intersections in the (u, u') -plane. The statements and proofs are presented for the extended Fisher–Kolmogorov equation, but the method can be directly extended to a wide class of fourth-order ordinary differential equations that derive from minimization problems.

Mathematics Subject Classification: 58E99, 34C99, 34C37, 37J45, 37J50

1. Introduction

Many higher-order ordinary differential equations are known to have a large number of bounded solutions on the real line. This feature has been extensively studied in equations such as the stationary extended Fisher–Kolmogorov (sEFK) equation and its generalizations and is found to be closely linked to the oscillatory nature of the solutions involved. Apart from being an interesting property in itself, this wealth of stationary states naturally raises the question in what ways this solution set can be structured. The most well known example of structuring can be found in classical bifurcation analysis, where one obtains information on continua of solutions in phase space. One might describe the results that are obtained within this framework as the creation of conceptual links between solutions that are close to each other in the space of solutions.

An alternative source of structure can be found in stability considerations. From this point of view solutions are classified not on the basis of their neighbours in solution space,

but according to their stability in a larger, dynamical, setting. For equations that are the Euler equation of an associated energy (as is the case for the sEFK equation) there is a convenient connection with the energy; up to degenerate cases, local stability in the dynamical setting is equivalent to local minimization of the energy. Local stability of stationary solutions of the extended Fisher–Kolmogorov (EFK) equation and its relatives has had a considerable amount of attention in the literature (see, e.g., [1–4]).

In this paper we restrict our view and limit ourselves to solutions that are *global* minimizers of an energy functional. Our goal is to demonstrate how the global minimization property imposes a form of monotonicity on the solution, thereby drastically limiting the set of potential global minimizers. To some extent this concept is modelled on the case of second-order problems in \mathbb{R}^n , where symmetrization techniques can be applied to prove that global minimizers are radially symmetric and monotonic in the radial variable.

We illustrate the concept on two model systems: (a) a model of an elastic strut supported by an elastic foundation; and (b) a model of pattern formation in polymeric materials under tension. Both examples concern the equation

$$u'''' + pu'' + F'(u) = 0 \quad \text{on } \mathbb{R} \quad (1)$$

which is also known as the stationary extended Fisher–Kolmogorov equation or the stationary Swift–Hohenberg equation, under various choices of nonlinearity F . Equation (1) arises in a variety of settings (besides the discussions in the later sections of this paper, see [5] for a review). It also has a Hamiltonian structure, where the Hamiltonian is given by

$$H = u'u'''' - \frac{1}{2}u''^2 + \frac{p}{2}u'^2 + F(u). \quad (2)$$

The core observation in this paper is a simple one: in a variational problem involving integrals of derivatives up to second order, a cut-and-paste argument is possible under the condition of C^1 -continuity. In order to locate candidates for such an argument one considers the solution in the (u, u') -plane; an intersection in this plane implies a point at which a switch can be made. In both of the examples below we use this switch to construct a contradiction of the property of global minimization; this rules out the existence of such intersection points, resulting in a statement that is reminiscent of monotonicity. A first application of a cut-and-paste argument for the specific question of global monotonicity can be found in [2, 6], for an unconstrained problem related to (1). The two problems we consider here both contain a constraint of some sort and as a result the argument is more delicate.

We should note that in addition to the interest of the results of this paper as an application of the cut-and-paste tool, the results that we obtain are of independent interest, both in the case of the elastic strut and in the case of the polymer patterns.

The structure of the rest of this paper is as follows. In sections 2 and 3 we introduce the model of an elastic strut on an elastic foundation and we state and prove our monotonicity results. In sections 4–6 we do the same for the polymer model.

2. An elastic strut on an elastic foundation

Structures consisting of thin elastic struts that are laterally supported appear in many different settings. Examples of such structures are railroad tracks and pipelines (a strut supported on one side) [7–9], suspension bridges (a strut suspended by springs) [10], sandwich structures (two plates surrounding a weaker material) [11, 12] and ‘single layers’ in geologic strata (a thin layer of a competent elastic material confined on both sides by thick layers of a weaker material) [13, 14].

The simplest and most common model for structures of this type features a one-dimensional linearly elastic strut supported by a purely local ('Winkler') elastic foundation. Let $u : \mathbb{R} \rightarrow \mathbb{R}$ describe the lateral deflection of an infinite-length strut; the strain energy W for this model is defined as

$$W(u) = \frac{1}{2} \int_{\mathbb{R}} u''^2 + \int_{\mathbb{R}} F(u).$$

The first integral models the strain energy associated with the bending of the strut, while the second represents the energy resulting from the deformation of the foundation. The function $F : \mathbb{R} \rightarrow \mathbb{R}$ is similar to the potential energy of an elastic spring; we will make assumptions on F below. We refer the reader to [14] for a detailed derivation of this model.

The classical 'rigid' or 'hard' loading problem consists of seeking the configuration with minimal strain energy subject to a displacement constraint:

$$\inf \{ W(u) : u \in H^2(\mathbb{R}), J(u) = \lambda \}. \quad (3)$$

Here $\lambda > 0$ is a parameter and the functional J ,

$$J(u) = \frac{1}{2} \int_{\mathbb{R}} u'^2$$

models the total shortening of the strut associated with a profile u . A minimizer of this constrained variational problem solves the associated Euler–Lagrange equation

$$W'(u) - pJ'(u) = 0 \quad (4)$$

where primes denote Fréchet derivation. The Lagrange multiplier $p \in \mathbb{R}$ can be interpreted physically as the load, or force, that has to be applied to the ends of the strut in order to equilibrate the profile u . This is similar to buckling a ruler between one's hands; a longitudinal force is required to maintain equilibrium. Equation (4) is equivalent to (1).

This constrained minimization problem was studied in [14], where it was shown that it is well posed for nonlinearities $F(u) = u^2/2 - u^4/4 + \alpha u^6/6$, $\alpha \geq \frac{3}{16}$. In the same paper a numerical algorithm was used (constrained gradient flow) to find solutions of (3). The algorithm itself only finds local minimizers; *a posteriori* comparison of the values of W is used to identify those that also minimize globally. Figure 1 shows some of the results obtained by this method.

The global minimizers in this figure share a common feature, that can be formulated in the following way. Let $x_i \in \mathbb{R}$, $i \in I \subset \mathbb{Z}$, be the x -values of the local minima and maxima of u , where x_i corresponds to a maximum if i is even and a minimum if i is odd. We observe in figure 1 that the sequence of maximal values $(u(x_{2i}))$ is what we shall henceforth call *bi-monotonic*: there exists an index $2i_0 \in I$, such that both $(u(x_{2i}))_{i \leq i_0}$ and $(u(x_{2i}))_{i \geq i_0}$ are monotonic. Similarly, the sequence of minimal values is also bi-monotonic.

The functions shown in figure 1 that are *not* global minimizers clearly do not share this feature. The main results of this paper state that this fact applies in a general manner and that every solution of (3) is bi-monotonic in this sense. In fact, we prove a stronger result.

Theorem 1. *Let F satisfy hypothesis F_1 below and let u solve (3). Then there exists $\bar{x} \in \mathbb{R}$ such that the function $x \mapsto (u(x), u'(x))$ is injective on $(-\infty, \bar{x}]$ and on $[\bar{x}, \infty)$.*

This result is depicted in figure 2. The bi-monotonicity of the maximal and minimal values is a consequence of theorem 1.

Corollary 2. *Under the conditions of theorem 1, both the sequence of maximal values and the sequence of minimal values are bi-monotonic.*

Global minimizers:



Local, non-global minimizers:

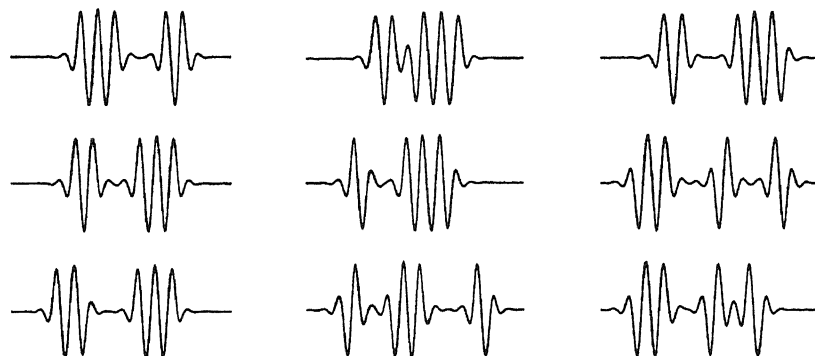

Figure 1. Local and global minimizers for the minimization problem (3) with nonlinearity $F(u) = u^2/2 - u^4/4 + 0.3 u^6/6$. The constraint values are in the region 7.5–8.5.

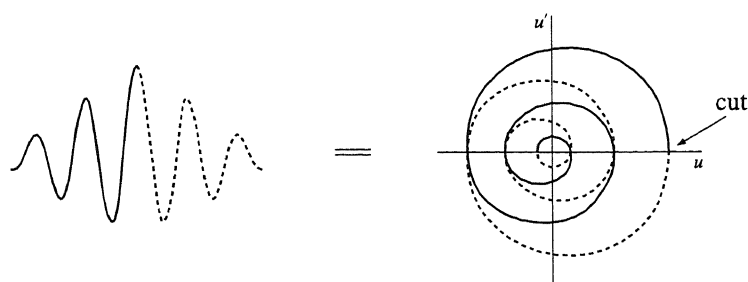

Figure 2. The statement of theorem 1: when the curve is cut at \bar{x} , the two resulting curves do not self-intersect.

Corollary 2 can be slightly sharpened in the direction of strict monotonicity; lemmas 4 and 5 give a more accurate statement.

Hypothesis F_1 . This hypothesis consists of the following two assumptions:

- (a) $F : \mathbb{R} \rightarrow \mathbb{R}$ is smooth, $F(u) \geq 0$ for all $u \in \mathbb{R}$ and $F(0) = 0$;
- (b) for any non-negative function $\phi \in L^1(\mathbb{R})$, such that $\text{supp } \phi$ is an interval, there exists $h \in \text{int}(\text{supp } \phi)$ such that

$$F * \phi(h) \leq F * \phi(0).$$

Part (b) of hypothesis F_1 can be interpreted in the following way. If $v : [0, T] \rightarrow \mathbb{R}$ is a given monotonic function, then we can write the function $h \mapsto W(v + h)$ using

$$W(v + h) = \frac{1}{2} \int_0^T v''^2 + \int_0^T F(v + h) = \frac{1}{2} \int_0^T v''^2 + \int_{\mathbb{R}} F(s) \phi(h - s) ds$$

where we define $\phi(-v(x)) = |1/v'(x)|$ for $0 \leq x \leq T$, with $\phi = 0$ outside the range $R(-v)$ of $-v$. Condition (b) implies that if 0 does not belong to $\text{int } R(v)$, then we can choose $h \in \mathbb{R}$ such that $0 \in \text{int } R(v+h)$, while decreasing the energy W . This hypothesis attributes a special place to the value zero in the function F .

Examples of functions F that satisfy hypothesis F_1 include all single-well potentials, such as the function used in [14], $F(u) = u^2/2 - u^4/4 + \alpha u^6/6$, for $\alpha \geq \frac{1}{4}$ and the ‘suspension-bridge’ nonlinearity $F(u) = e^u - u - 1$ [15]. For multiple-well potentials the situation is slightly more delicate; in the case of the sixth-order polynomial above, the hypothesis is satisfied for $\alpha = \frac{1}{4} - \varepsilon$, but not for $\alpha = \frac{3}{16} + \varepsilon$ (the positivity condition $F \geq 0$ is equivalent to $\alpha \geq \frac{3}{16}$). We comment further on hypothesis F_1 in remark 6 after the proof of theorem 1.

Remark 3. In [14] it was proved that as $\lambda \rightarrow \infty$, solutions of (3) exhibit a form of convergence. If we choose a solution u_λ for every $\lambda > 0$ (note that solutions of (3) are not necessarily unique and that the set $\{u_\lambda\}_{\lambda>0}$ need not be a continuum), then for any sequence $\lambda_n \rightarrow \infty$ there exists a subsequence $\lambda_{n'}$ such that, after an appropriate translation,

$$u_{\lambda_{n'}} \rightarrow u_\infty \quad \text{uniformly on compact sets.}$$

The function u_∞ is periodic on \mathbb{R} and is characterized as a solution of the minimization problem

$$p_M := \inf \left\{ \frac{\int_0^T [\frac{1}{2}v''^2 + F(v)]}{\frac{1}{2} \int_0^T v'^2} : T > 0, v \in H^2(\mathbb{R}) \text{ is periodic with period } T \right\}. \quad (5)$$

This convergence can be recognized in figure 3(a).

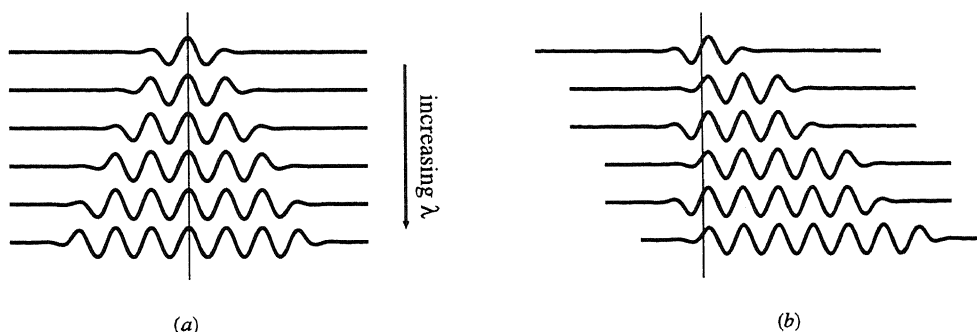

Figure 3. Solutions of (3) for different values of λ , for the nonlinearity $F(u) = u^2/2 - u^4/4 + 0.3 u^6/6$. The vertical lines indicate the different choices of translations: in (a) the solutions are aligned on their maximum and in (b) on a smallness condition to the left of the line.

While in [14] it was not possible to prove more than this, the present results allow us to strengthen this convergence, most importantly by allowing for a different translation with a different limit. We choose a small $\varepsilon > 0$ and fix the translation of u_λ by imposing $|u_\lambda(0)| = \varepsilon$ and $|u_\lambda(x)| < \varepsilon$ for all $x < 0$. The monotonicity result of corollary 2 implies that the ‘mass’ of the integral $J(u_\lambda)$ remains localized; therefore we can use an argument similar to that in [14] to conclude that a subsequence $u_{\lambda_{n'}}$ converges uniformly on compact sets to a (different) limit function v_∞ (figure 3(b)).

The limit function v_∞ is necessarily monotonic, in the sense of this paper—i.e. the sequence of maximal values is increasing and the image in the u, u' -plane does not intersect itself. If u_∞ , as defined by (5), is unique, then an additional argument can be used to show that $v_\infty(x) \rightarrow 0$ as $x \rightarrow -\infty$ and $v_\infty(x) \rightarrow u_\infty(x)$ as $x \rightarrow \infty$ (the latter up to a translation).

Formulated differently, the limit function v_∞ is a heteroclinic connection¹ between zero and u_∞ .

3. Proof of theorem 1

We introduce some notation. Our main tools are sections of solutions that we describe as elements of the set

$$U := \{(v, D(v)) : D(v) \subset \mathbb{R} \text{ is a closed interval, } v \in C^1(D(v))\}.$$

In this definition of U we explicitly include the domain $D(v)$, but when there is no risk of confusion we shall denote an element $(v, D(v))$ simply by v . For $v \in U$ we define $\gamma_v : D(v) \rightarrow \mathbb{R}^2$, $\gamma_v(x) = (v(x), v'(x))$.

Sections can be cut (or extracted) out of others by the natural *restriction operator*: if $v \in U$ and $I \subset D(v)$, then $v|_I = (v, I)$ is the restriction of v to I . The opposite is the *concatenation operator*: if $v_1, v_2 \in U$, if $\sup D(v_1)$ and $\inf D(v_2)$ are both finite and if the continuity condition

$$\gamma_{v_1}(\sup D(v_1)) = \gamma_{v_2}(\inf D(v_2)) \tag{6}$$

is satisfied, then the concatenation is defined as

$$v_1 \odot v_2 := (v, I)$$

where I is the concatenation of $D(v_1)$ and $D(v_2)$,

$$I = D(v_1) \cup (D(v_2) - \inf D(v_2) + \sup D(v_1))$$

and

$$v = \begin{cases} v_1(x) & x \in D(v_1) \\ v_2(x - \sup D(v_1) + \inf D(v_2)) & x \in I \setminus D(v_1). \end{cases}$$

By condition (6) we have $v_1 \odot v_2 \in U$. This operator extends in a natural way to three or more arguments, with the coordinate system of the result being that of the first argument.

For $(v, D(v)) \in U$ we define in a natural manner $W(v) = \int_{D(v)} [\frac{1}{2}v''^2 + F(v)]$ (and similarly $J(v)$). We shall often write $W_I(v)$ instead of the more cumbersome notation $W(v|_I)$.

Proof of theorem 1. Recall the notation that was introduced in the previous section: let $x_i \in \mathbb{R}$, $i \in I \subset \mathbb{Z}$, be the x -values of the strict local minima and maxima of u , where x_i corresponds to a maximum if i is even and a minimum if i is odd. The function u then is increasing on $[x_{2i-1}, x_{2i}]$ and decreasing on $[x_{2i}, x_{2i+1}]$. We first prove an intermediate result.

Lemma 4. For all $2i_0 \in I$ such that $2i_0 \pm 2 \in I$ we have

$$z_{2i_0} \geq \min(z_{2i_0-2}, z_{2i_0+2}).$$

Proof. Suppose that there exists $2i_0 \in I$ that contradicts this statement, i.e. $z_{2i_0} < \min(z_{2i_0-2}, z_{2i_0+2})$. It follows from this inequality that the curve γ_u has a topologically transverse intersection (an intersection which persists under perturbation) in (x_{2i_0-2}, x_{2i_0+2}) (see figure 4), i.e. there exist $y_1, y_2 \in (x_{2i_0-2}, x_{2i_0+2})$ with $\gamma_u(y_1) = \gamma_u(y_2)$. We now define

$$\tilde{u} = u|_{(-\infty, y_1]} \odot u|_{[y_2, \infty)}$$

¹ This function, in fact, minimizes $L_{\mathbb{R}}(u)$ (when defined in an appropriate fashion), for the load $p = p_M$ (the *Maxwell load*, given by (5); see [14, 16] for a discussion of this concept) and is therefore also a c -optimal minimizer, as defined in section 4.

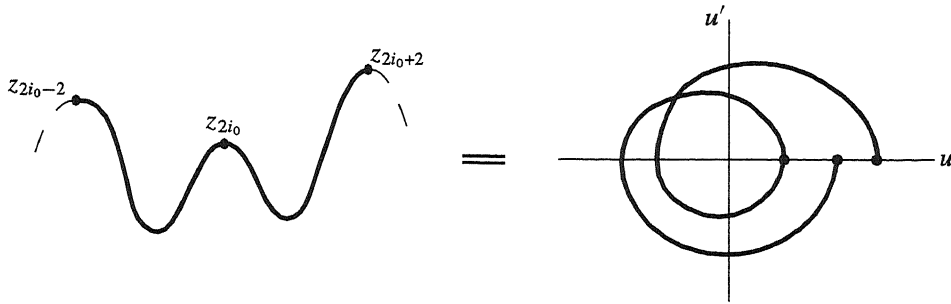

Figure 4. The ordering of the maxima implies the existence of an intersection in the u, u' -plane.

and

$$v = u|_{[y_1, y_2]}.$$

From the inequality $z_{2i_0} < \min(z_{2i_0-2}, z_{2i_0+2})$ it also follows that

$$\inf \tilde{u} \leq \inf v < \sup v < \sup \tilde{u}.$$

The function γ_v maps the interval $[y_1, y_2]$ to a closed curve in the plane. Hypothesis F_1 allows us to assume that $(0, 0)$ lies inside this curve: if $\inf v \geq 0$ or $\sup v \leq 0$, then there exists $h \in \mathbb{R}$ such that $W_{[y_1, y_2]}(v+h) \leq W_{[y_1, y_2]}(v)$ and $\inf v+h < 0 < \sup v+h$. The new function $\tilde{v} = v+h$ again corresponds to a closed curve in \mathbb{R}^2 , containing the origin. By construction at least one of the points $(\inf \tilde{u}, 0)$ and $(\sup \tilde{u}, 0)$ lies outside this curve; the former if $h > 0$ and the latter if $h \leq 0$.

We are interested in intersections of \tilde{u} with \tilde{v} . The fact that \tilde{u} connects two points of which one is outside the curve and the other is inside it implies that \tilde{u} and \tilde{v} intersect. There is a slight pitfall, however: if $h = 0$, then there is one intersection that we have already encountered and which we have used to break u into the two parts \tilde{u} and v : $\gamma_{\tilde{u}}(y_1) = \gamma_v(y_1)$. If $h = 0$ then $\tilde{v} = v$ and this intersection still exists. However, the assumption that the initial intersection was topologically transverse implies that the opposite is true for this intersection of \tilde{u} and v .

We conclude from this argument that there exists a (different) intersection point, i.e. there exists $y_3 \in \mathbb{R}, y_3 \neq y_1$ and $y_4 \in [y_1, y_2]$ such that $\gamma_{\tilde{u}}(y_3) = \gamma_{\tilde{v}}(y_4)$. We then construct

$$\tilde{u} = \tilde{u}|_{(-\infty, y_3]} \odot \tilde{v}|_{[y_4, y_4+T]} \odot \tilde{u}|_{[y_3, \infty)}.$$

Here we implicitly extend \tilde{v} outside $[y_1, y_2]$ by concatenating translated copies of itself, thus creating a periodic function with period $T = y_2 - y_1$.

By tracking the shuffling of sections above it follows that $W(\tilde{u}) \leq W(u)$ and $J(\tilde{u}) = J(u)$, so that \tilde{u} is also a solution of (3). However, the concatenation cannot be of class C^3 , since this would imply local uniqueness and therefore $\tilde{u} \equiv u$. It follows that $W - pJ$ is not stationary at \tilde{u} and therefore \tilde{u} is not optimal, implying a contradiction. \square

Lemma 5. *Let $z_{2i} = z_{2i+2}$. Then $z_{2i} = \sup u$ and u is even with respect to $x = (x_i + x_{i+2})/2$.*

Proof. First we prove that u is even. Define

$$\tilde{u} = \begin{cases} u(x) & x \leq x_i \text{ or } x \geq x_{i+2} \\ u(x_i + x_{i+2} - x) & x_i \leq x \leq x_{i+2}. \end{cases}$$

We have $\tilde{u} \in C^1(\mathbb{R})$, $W(\tilde{u}) = W(u)$ and $J(\tilde{u}) = J(u)$, so that \tilde{u} is optimal; by local uniqueness this implies that $u(x) = u(x_i + x_{i+2} - x)$ for $x \geq x_{2i+2}$, which is equivalent to the statement that u is even with respect to $(x_i + x_{i+2})/2$. It also follows that the equation $z_i = z_{i+2}$ can have at most one solution i .

Now suppose that $z_{2i} < \sup u$. Along similar lines as in the previous proof, we define

$$\tilde{u} = u|_{(-\infty, x_{2i}]} \odot u|_{[x_{2i+2}, \infty)} \quad \text{and} \quad v = u|_{[x_{2i}, x_{2i+2}]}$$

We have by assumption

$$\sup v < \sup \tilde{u};$$

we split up the proof on the basis of the inequality $\inf \tilde{u} \geq \inf v$.

If $\inf \tilde{u} \leq \inf v$, then the two functions \tilde{u} and v are similar to the case of the proof of lemma 4 and by following the argument through we obtain a contradiction.

If $\inf \tilde{u} > \inf v$, then we again apply a similar argument, but with a slight variation: the point $(\inf \tilde{u}, 0)$ lies inside the curve described by γ_v and $(\sup \tilde{u}, 0)$ lies outside this curve. The rest of the argument is similar. □

The combination of lemmas 4 and 5 implies that (z_{2i}) is a bi-monotonic sequence; if z_{2i_0} is the sole maximum of this sequence, then $(z_{2i})_{i \leq i_0}$ and $(z_{2i})_{i \geq i_0}$ are strictly monotonic sequences; if $z_{2i_0} = z_{2i_0+2}$, then $(z_{2i})_{i \leq i_0}$ and $(z_{2i})_{i \geq i_0+1}$ are strictly monotonic. A similar argument holds for (z_{2i+1}) . Note that these results also imply that $(-1)^i z_i \geq 0$.

To finish the proof of theorem 1 we pick a value for \bar{x} . If z_{2i_0} is the sole maximum of u , then let $\bar{i} = 2i_0$; if $z_{2i_0} = z_{2i_0+2}$, then we set $\bar{i} = 2i_0 + 1$. We then set $\bar{x} = x_{\bar{i}}$. This choice implies that the sequences $(z_{2i})_{2i \geq \bar{i}}$, $(z_{2i})_{2i \leq \bar{i}}$, $(z_{2i+1})_{2i+1 \geq \bar{i}}$ and $(z_{2i+1})_{2i+1 \leq \bar{i}}$ are each *strictly* monotonic.

Suppose that there exist $\bar{x} < y_1 < y_2$, $y_1 \in (x_{i_1}, x_{i_1+1})$ and $y_2 \in (x_{i_2}, x_{i_2+1})$ with $\gamma_u(y_1) = \gamma_u(y_2)$. If the two sections of the curve γ_u intersect non-transversally, then $(u, u', u'')(y_1) = (u, u', u'')(y_2)$; since the Hamiltonian H is constant along u and since $u'(y_1) \neq 0$, it follows that u''' is also equal at y_1 and y_2 . This implies that u is periodic, which is ruled out by assumption. This contradiction proves the theorem for this case.

In the alternative case, that is if the two sections of γ_u intersect transversally, the monotonicity of (z_{2i}) and (z_{2i+1}) implies that the intersections come in pairs: there also exist $y'_1 \in (x_{i_1}, x_{i_1+1})$ and $y'_2 \in (x_{i_2}, x_{i_2+1})$, different from y_1 and y_2 , with $\gamma_u(y'_1) = \gamma_u(y'_2)$ and satisfying $(y_1 - y'_1)(y_2 - y'_2) > 0$. Assume for definiteness that $y_1 < y'_1$, which implies the ordering

$$x_{i_1} < y_1 < y'_1 < x_{i_1+1} < x_{i_2} < y_2 < y'_2 < x_{i_2+1}.$$

We then construct a contradiction along now familiar lines by defining

$$\tilde{u} = u|_{(-\infty, y_1]} \odot u|_{[y_2, y'_2]} \odot u|_{[y'_1, y_2]} \odot u|_{[y_1, y'_1]} \odot u|_{[y'_2, \infty)}.$$

This concludes the proof of theorem 1. □

Remark 6. The function ϕ in hypothesis F_1 is associated with the function v that appears in the proof of lemma 4. It represents the reciprocal of the derivative v' when considered as a function of v on a monotonic section. If more is known about v than the bare minimum, then the conditions on ϕ in hypothesis F_1 can be more stringent and the class of functions F_1 satisfying hypothesis F_1 therefore larger. We discuss two examples.

- (a) If it is known *a priori* that the load p associated with the solution u (and therefore also with v , which is a restriction of u) is non-negative, then on an increasing section v' is a concave function of v (this follows from a transformation of the equation $H = 0$ into the u, u' -plane; see, e.g., [3, appendix 2]). Therefore, $\phi = 1/v'$ is a convex function of v on $[\inf u, \sup u]$. This constitutes an additional condition on ϕ in the formulation of hypothesis F_1 .
- (b) More generally, instead of simply translating v by adding a constant, we could replace v by the solution \bar{v} of

$$\inf \{W(\bar{v}) : T > 0, \bar{v} \in H^2(0, T), (\bar{v}, \bar{v}')(0) = (\bar{v}, \bar{v}')(T), J(\bar{v}) = J(v)\}.$$

Since v is a candidate in this minimization problem we have $W(\bar{v}) \leq W(v)$.

If we know, by other means, that the range $\text{int } R(\bar{v})$ contains zero, then the argument of the proof of lemma 4 continues unchanged. Unfortunately, no result is currently known to us that specifies conditions such that $0 \in \text{int } R(\bar{v})$ for a general multi-well potential. We leave this for future study.

4. Patterns in polymeric materials under tension

The second example that we discuss is taken from the theory of thermodynamic equilibrium states of so-called ‘second-order materials’ [17–26]. We introduce these models by briefly dwelling on the phenomenon of *necking* in polymer fibres.

An essential step in the production of polymer fibres is the *drawing* process, in which fibres of unordered (unaligned) polymer are extended with the aim of aligning the polymer chains and thus increasing the tensile strength of the fibre. The state of slow homogeneous extension can be unstable, leading to ‘necking’: at one or more places along the length of the fibre the thickness locally decreases. The extension then concentrates at these necks, which lengthen and further decrease in thickness. In contrast to plastic yielding in metals this does not necessarily result in a total failure at the neck; the thinning may halt at a critical thickness, corresponding to a highly aligned polymer state. Under continued drawing the material in the neck then no longer deforms, but the overall extension takes place by migration of the thick–thin transitions into the thick state.

A common model for this phenomenon [17, 18] considers a fibre of infinite length, parametrized by a Lagrangian coordinate $x \in \mathbb{R}$. The unknown $u : \mathbb{R} \rightarrow \mathbb{R}$ represents the longitudinal strain due to stretching; the lateral deformation due to thinning is taken into account via the choice of functional to be minimized. This leads to minimization problems of the form given below.

Definition 7. A function $u \in H_{\text{loc}}^2(\mathbb{R})$ is an equilibrium state if it achieves the minimum in the minimization problem

$$\mu := \inf \{Q(u) : u \in H_{\text{loc}}^2(\mathbb{R})\} \quad (7)$$

where

$$Q(u) := \liminf_{T \rightarrow \infty} \frac{1}{2T} L_{[-T, T]}(u)$$

and

$$L_{[-T, T]}(u) := \int_{-T}^T \ell(u, u', u''). \quad (8)$$

A traditional choice for ℓ is

$$\ell(u, u', u'') = \nu(u)u'^2 + F(u). \quad (9)$$

Since this expression does not depend on u'' , such a material is said to be 'of first order'. For functions ν and F that are positive the problem (7)–(9) has been considered in [27].

In a number of subsequent papers, as mentioned at the beginning of this section, extensions of this framework are considered in which ν can take negative values. For the minimization problem (7) to have solutions a dependence on u'' is added, resulting in the more general 'second-order' materials. Here the canonical example, to which we shall restrict ourselves in this paper, is

$$\ell(u, u', u'') = \frac{1}{2}u''^2 - \frac{p}{2}u'^2 + F(u). \quad (10)$$

Any expression of the form $au''^2 - bu'^2 + F(u)$ can be reduced to this form; we choose (10) so that the associated Euler equation will again be (1). Note that in the notation of the previous sections we have

$$L = W - pJ.$$

Hypothesis F_2 . Throughout the rest of this paper we assume that F satisfies hypothesis F_2 ,

$$F \text{ is smooth and } F(s)s^{-2} \rightarrow \infty \text{ as } |s| \rightarrow \infty.$$

The parameter p is an arbitrary real scalar.

Regardless of the choice of ℓ , the formulation of definition 7 defines a class of equilibrium states that is too large to be of direct use. To illustrate this, suppose that u is an equilibrium state and that $v \in C_c^\infty(\mathbb{R})$; then $u + v$ is again an equilibrium state. This shows that the formulation of definition 7 provides no information on bounded sets. A refinement was therefore proposed in [17].

Definition 8. A function $u \in H_{\text{loc}}^2(\mathbb{R})$ is a c -optimal minimizer (or a minimizer on compact sets) of Q if

- (a) u achieves the minimum of Q and
- (b) for each bounded interval I , u achieves the minimum in the problem

$$\inf\{L_I(v) : v \in H^2(I), (v, v') = (u, u') \text{ on } \partial I\}.$$

C -optimal minimizers satisfy $L'_\mathbb{R}(u) \cdot \varphi = 0$ for all $\varphi \in C_c^\infty(\mathbb{R})$ and therefore solve equation (1). In the papers mentioned above these c -optimal minimizers are viewed as the basic objects of study and here we shall do likewise.

A considerable amount of effort has been invested in obtaining various kinds of information on c -optimal minimizers. The question of the existence of such solutions has been answered positively in [17] and in [23] multiplicity results are given. In [17, 20] it was shown that there exist c -optimal minimizers that are periodic. By [23, theorem C] these periodic solutions are symmetric with respect to any local minimum or maximum, so that they can be described as symmetric periodic extensions of solutions of the minimization problem

$$\inf\{L_{[0, T]}(v) : T > 0, v : [0, T] \rightarrow \mathbb{R} \text{ is monotonic, } v'(0) = v'(T) = 0\}. \quad (11)$$

Note that the half-period T is free. Depending on p and F the minimum in (11) might be achieved by a constant function or by a non-constant half-periodic function [17, 23].

The minimizers of the half-periodic problem (11) are encountered in the limits $x \rightarrow \pm\infty$.

Lemma 9 (see [17]). *Let u be a c -optimal minimizer. There exist $x_n \rightarrow \infty$, $T_n > 0$, such that u is monotonic on $[x_n, x_n + T_n]$, $u'(x_n) = u'(x_n + T_n) = 0$, the sequence T_n converges to a limit T and $u(\cdot - x_n)$ converges on compact sets to a $2T$ -periodic function w . The function w achieves the minimum in (11).*

Other examples of information that has been derived are boundedness in $C^1(\mathbb{R})$ (see [24] and [20, proposition 3.1]), boundedness and equidistribution of ‘local energy’ L_I [24] and uniqueness of minimizers of (11) for ‘generic’ functions F [25].

5. Results

In this paper we add two results to this list. The first is an intermediate result with some independent interest.

Theorem 10. *Let F satisfy hypothesis F_2 and let u be a c -optimal minimizer. Then u solves (1) and the associated Hamiltonian (2) is equal to μ on \mathbb{R} .*

The main statement here is the particular value of the Hamiltonian, which is the constant μ given by (7). An immediate consequence is that many of the non-constant solutions that were constructed in [23] are not c -optimal, since they have a different value of H . In remark 15 we discuss extensions of the results of this paper to more general functions ℓ and there we also comment on the significance of this specific value of the Hamiltonian.

Our main result is one of monotonicity similar to that of sections 2 and 3.

Theorem 11. *Let F satisfy hypothesis F_2 and let u be a c -optimal minimizer. Then one of the following three alternatives holds:*

- (a) u is constant;
- (b) u is periodic; or
- (c) the curve $\{(u(x), u'(x)) \in \mathbb{R}^2 : x \in \mathbb{R}\}$ has no self-intersections.

Before proving these theorems, in section 6, we discuss some of the implications of theorem 11. We define the limit states of a c -optimal solution u by

$$\omega_{\pm} := \bigcap_{T>0} \overline{\{(u(x), u'(x)) : \pm x \geq T\}}.$$

First we consider the limit states themselves. It is a classical result in dynamical system theory that the ω -limit set of a single trajectory is a union of entire solutions (i.e. solutions on \mathbb{R}) of the dynamical system. Lemma 9 provides a certain amount of information on the ω -limit set, but it leaves open the possibility that this union contains more than a single solution. Theorem 11 allows us to partially rule out this possibility.

Corollary 12. *Under the conditions of theorem 11, the limit state ω_+ is a simple closed curve in the plane (which might be degenerate, i.e. a point); along this curve u has a single local maximum and a single local minimum. The same holds for ω_- .*

Proof. If u is monotonic near $+\infty$, then ω_+ is a singleton and the corollary is proved; we therefore suppose that u oscillates at $+\infty$, i.e. that u' continues to change sign. We can construct an infinite sequence of closed curves in \mathbb{R}^2 that act as barriers by exploiting the direction of solution curves in the plane; this is illustrated by figure 5. There are only two possibilities: the curve spirals either inward or outward. In both cases the set ω_+ is the limit set

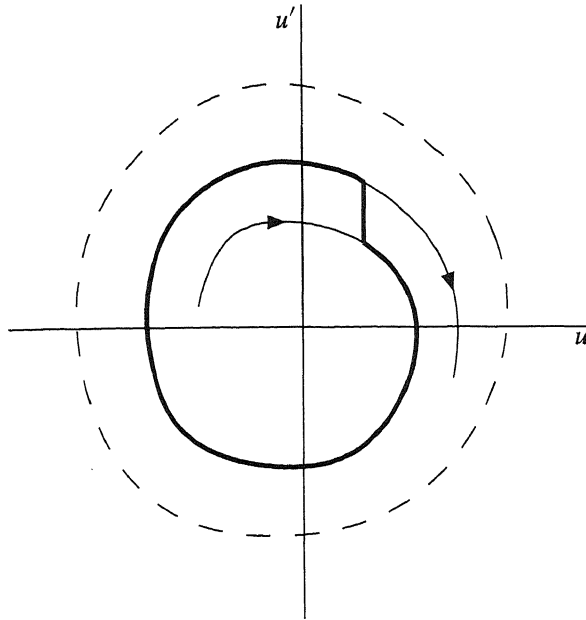

Figure 5. In the half-plane $\{u' > 0\}$ the solution curve moves to the right. Therefore, the closed curve forms a barrier that the solution curve cannot pass. The limit state (broken curve) is the limit of such closed curves.

in \mathbb{R}^2 of this sequence of simple closed curves; since the regularity of these curves is bounded when u' is bounded away from zero, the limit set therefore is a simple closed curve itself. \square

Secondly, the non-intersection result implies that the set of all c -optimal minimizers reduces to a bare minimum when $\omega_- = \omega_+$.

Corollary 13. *If a c -optimal minimizer is homoclinic to a constant state, then it is constant; if it is homoclinic to a periodic state, then it is periodic.*

Proof. The second part of this corollary follows immediately from the observation that if $\omega_- = \omega_+$ is not a singleton, then intersections are unavoidable. By theorem 11 the solution is therefore periodic.

For the first part the same is true if one of the tails oscillates. If both are monotonic, however, a slightly different argument is called for. The stable and unstable manifolds of a well for equation (1) can only contain monotonic solutions if $p \leq 0$; but if p is non-positive, then all c -optimal minimizers are constant. \square

Corollary 13 seems slightly strange in the light of the following question. Let ϕ be a solution of (11) and define the phase-shifted version

$$\tilde{\phi}(x) = \begin{cases} \phi(x) & x \leq -1 \\ \phi(x + a) & x \geq 1 \end{cases} \tag{12}$$

for some $a \in \mathbb{R}$. What then happens to the sequence of functions u_n , defined by

$$u_n = \begin{cases} \tilde{\phi} & \text{on } (-\infty, -n] \cup [n, \infty) \\ \text{minimal for } L_{[-n,n]} & \text{on } [-n, n]? \end{cases}$$

If the sequence u_n respects the phase difference in $\tilde{\phi}$, then a non-trivial homoclinic orbit to ϕ results, in contradiction with corollary 13.

The answer is given in the proof of theorem 11. The cost of changing wavelength in ϕ (i.e. rescaling x but not ϕ) by a factor $1 + \varepsilon$ is quadratic in ε . By spreading it over a large number of periods, the total cost of a given phase shift can be made arbitrarily small. Thus the sequence u_n ‘corrects’ the phase mismatch of $\tilde{\phi}$.

Note that this contrasts with the case of limit values that differ by more than a phase shift. If we repeat the argument with a function

$$\tilde{\phi}(x) = \begin{cases} \phi_1(x) & x \leq -1 \\ \phi_2(x) & x \geq 1 \end{cases}$$

where $\phi_{1,2}$ are distinct solutions of (11), then we find that a homoclinic solution is possible (see remark 3 for an example). In this case the mismatch cannot be corrected by adding a large number of small perturbations to the limit states $\phi_{1,2}$; an $O(1)$ change is needed in the cross-over region and consequently the argument given above does not apply.

Finally, in [25] the authors demonstrate for a class of systems of the general form (8) that the periodic minimization problem (11) generically has a unique solution (the term ‘generically’ should be understood in terms of the choice of the function F). In such a case the limit states of a c-optimal minimizer are necessarily given by this periodic function.

Corollary 14. *Suppose that the solution of (11) is unique (up to translation). Then the only c-optimal minimizers are translations of this periodic solution.*

Corollaries 12–14 were also stated in [23] and proved in [25].

6. Proofs of theorems 10 and 11

In addition to assuming hypothesis F_2 , we shall wish to *normalize* F , which means to replace F by

$$\tilde{F} := F - \mu$$

and drop the tilde (μ is the limit value in (7)). By doing this we can assume without loss of generality that $\mu = 0$, which simplifies notation.

We first prove theorem 10; note that the redefinition of F has changed the assertion of the theorem into ‘ $H = 0$ ’.

Proof of theorem 10. It was mentioned above that u satisfies equation (1). C-optimal minimizers are bounded on \mathbb{R} and therefore standard elliptic estimates imply that all derivatives of u are bounded on \mathbb{R} .

Suppose that $H \neq 0$ and first assume that $H < 0$. If we define the ‘stretched’ version of u ,

$$u_\lambda(x) = u(x/\lambda)$$

then

$$\begin{aligned} L_{[0,\lambda T]}(u_\lambda) &= \int_0^{\lambda T} \left[\frac{1}{2} \frac{1}{\lambda^4} u''(x/\lambda)^2 - \frac{P}{2} \frac{1}{\lambda^2} u'(x/\lambda)^2 + F(u(x/\lambda)) \right] dx \\ &= \int_0^T \left[\frac{1}{2\lambda^3} u''(y)^2 - \frac{P}{2\lambda} u'(y)^2 + \lambda F(u(y)) \right] dy \end{aligned}$$

so that

$$\begin{aligned} \frac{d}{d\lambda} L_{[0,\lambda T]}(u_\lambda) \Big|_{\lambda=1} &= \int_0^T \left[-\frac{3}{2} u''(y)^2 + \frac{P}{2} u'(y)^2 + F(u(y)) \right] dy \\ &= \int_0^T \left[u'''(y)u'(y) - \frac{1}{2} u''(y)^2 + \frac{P}{2} u'(y)^2 + F(u(y)) \right] dy - [u''u']_0^T \\ &= TH - [u''u']_0^T. \end{aligned} \tag{13}$$

By a similar calculation and taking into account that all derivatives of u are bounded on \mathbb{R} , we have

$$\frac{d^2}{d\lambda^2} L_{[0,\lambda T]}(u_\lambda) \Big|_{\lambda=1} \leq CT$$

where $C > 0$ is independent of T . Therefore, we can choose $\varepsilon, T_0 > 0$ such that

$$L_{[0,(1+\varepsilon)T]}(u_{1+\varepsilon}) \leq L_{[0,T]}(u) + \frac{1}{2}\varepsilon TH \quad \text{for all } T > T_0.$$

We now construct a new function v :

$$v(x) := \begin{cases} u(x) & x < -1 \\ u_{1+\varepsilon}(x) & 0 < x < (1+\varepsilon)T \\ u(x) & x > (1+\varepsilon)T + 1. \end{cases}$$

On the interval $(-1, 0)$ we construct a C^1 -connection between $u(-1)$ and $u_{1+\varepsilon}(0)$. Similarly, we construct a C^1 -connection between $u_{1+\varepsilon}((1+\varepsilon)T)$ and $u((1+\varepsilon)T + 1)$; here we can assume that $L_{[(1+\varepsilon)T,(1+\varepsilon)T+1]}(v)$ is bounded independently of T . By choosing T sufficiently large we find

$$L_{[-1,(1+\varepsilon)T+1]}(v) < L_{[-1,(1+\varepsilon)T+1]}(u)$$

which contradicts the optimality of u .

In the case $H > 0$ we use a similar perturbation, but in the opposite sense: the function $u|_{[0,T]}$ is compressed instead of extended ($\varepsilon < 0$). In this case there is a gap to be filled (see figure 6). By lemma 9 we can find an interval $[x', x' + T']$ on which u is monotonic, $u'(x') = u'(x' + T') = 0$ and

$$L_{[x',x'+T']}(u) \leq \frac{1}{4} |\varepsilon| T' H.$$

By replicating this monotonic section (locally) as in figure 6 the gap can be closed; the cost, in terms of L , of this replication is bounded by

$$\frac{T}{T'} L_{[x',x'+T']}(u) \leq \frac{1}{4} |\varepsilon| T H.$$

The argument then proceeds analogously. □

Proof of theorem 11. We place ourselves in the position of theorem 11 and we suppose that u is neither constant nor periodic. Note that u solves (1) and that the constant Hamiltonian is equal to zero by theorem 10.

Suppose there is an intersection, i.e. there exist $x_1, x_2 \in \mathbb{R}, x_1 < x_2$, such that $\gamma_u(x_1) = \gamma_u(x_2)$. Then consider

$$v = u|_{(-\infty,x_1]} \odot u|_{[x_2,\infty)}.$$

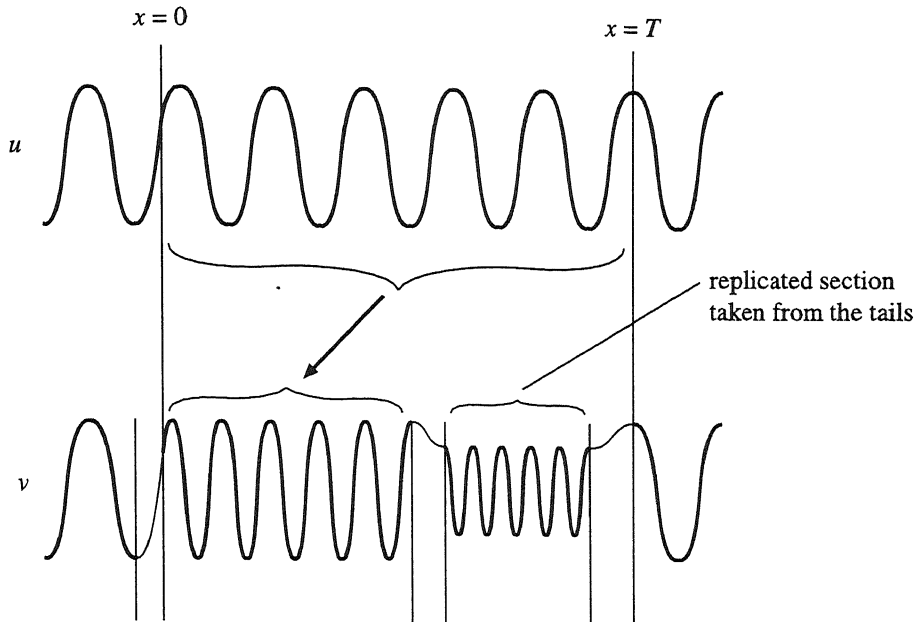

Figure 6. In the case $H > 0$ the original function u is compressed; a near-optimal section is taken from the tails and replicated to fill the gap.

Since $\mu = 0$, the functional L is non-negative on any periodic function, so that

$$L_{[x_1-1, x_1+1]}(v) = L_{[x_1-1, x_2+1]}(u) - L_{[x_1, x_2]}(u) \leq L_{[x_1-1, x_2+1]}(u). \tag{14}$$

The function v also solves equation (1) for all $x \neq x_1$. If v has a C^3 -connection at x_1 , then by local uniqueness we have $v|_{x \geq x_1} \equiv u|_{x \geq x_1}$; this implies that $u|_{x \geq x_2}$ is equal to a translated version of $u|_{x \geq x_1}$ and therefore that u is constant or periodic. This is ruled out by assumption and we conclude that v does not have a C^3 -connection at $x = x_1$. We can therefore perturb v on $(x_1 - 1, x_1 + 1)$ to obtain a strict inequality in (14) and in the following we assume that this has been done. Note that by construction the Hamiltonian $H(v)$ is equal to zero on $(-\infty, x_1 - 1) \cup (x_1 + 1, \infty)$.

We now split the argument into two cases. First suppose that u' is of one sign for $x \rightarrow \infty$; this implies that u converges to a constant $u(\infty)$ and the assumption $\mu = 0$ implies that $F(u(\infty)) = 0$. Since $u'(x) \rightarrow 0$ as $x \rightarrow \infty$, by choosing $T > 1$ sufficiently large we can find a function $w \in C^2([0, x_2 - x_1])$, with $\gamma_w(0) = \gamma_w(x_2 - x_1) = \gamma_v(T)$, such that $L_{[0, x_2 - x_1]}(w)$ is arbitrarily small. Define

$$z = v|_{(-\infty, T]} \odot w|_{[0, x_2 - x_1]} \odot v|_{[T, \infty)}.$$

Then $z \equiv u$ on $(-\infty, x_1 - 1] \cup [T + x_2 - x_1, \infty)$ and

$$L_{[x_1-1, T+x_2-x_1]}(z) = L_{[x_1-1, x_1+1]}(v) + L_{[x_1+1, T]}(v) + L_{[0, x_2-x_1]}(w).$$

By choosing T sufficiently large (so that $L_{[0, x_2 - x_1]}(w)$ can be taken sufficiently small) the right-hand side of this expression is less than $L_{[x_1-1, T+x_2-x_1]}(u)$.

We next consider the alternative situation, in which u oscillates at ∞ , i.e. u' continues to change sign as $x \rightarrow \infty$. We choose $y_1 > x_1 + 1$ such that $u'(y_1) = 0$ and $T > 0$ (destined to

be large) such that $u'(y_1 + T) = 0$. We now stretch the region $(y_1, y_1 + T)$ of v to compensate for the shortening:

$$w(x) = \begin{cases} v(x) & x \leq y_1 \\ v(y_1 + (x - y_1)/\lambda) & y_1 < x < y_1 + \lambda T \\ v(x - (\lambda - 1)T) & x \geq y_1 + \lambda T \end{cases}$$

with $\lambda = 1 + (x_2 - x_1)/T$. The connections at y_1 and at $y_1 + T$ are of class C^1 since u is stationary at these points. Note that w and u coincide on $(-\infty, x_1 - 1] \cup [y_1 + T, \infty)$. Since $H(u) = 0$ and using

$$\left. \frac{d^2}{d\lambda^2} L_{[y_1, y_1 + \lambda T]}(v) \right|_{\lambda=1} \leq CT$$

we have

$$L_{[y_1, y_1 + T]}(w) - L_{[y_1, y_1 + T]}(v) \leq CT(\lambda - 1)^2$$

provided T is large. Since $\lambda - 1 = O(T^{-1})$ we can choose T large enough for

$$L_{[x_1 - 1, y_1 + T]}(w) < L_{[x_1 - 1, y_1 + T]}(u)$$

to hold, contradicting the assumption that u is c -optimal. This concludes the proof of theorem 11. \square

Remark 15. Many of the papers on patterns in second-order polymeric materials that are mentioned above consider functionals L of a more general form than those considered here. We chose the simple integrand (10) for the simplicity of exposition and the connection with other, well known aspects of equation (1) (among which the results of sections 2 and 3 of this paper). Let us briefly discuss the potential for generalization of the results of this section.

The two key elements in the proof of theorem 11 are the intersection argument and the fact that $H = 0$ (when F has been normalized). First consider the intersection argument. The choice of the integrand in (8) has consequences for the character of the associated Euler equation. In a general sense, if the Euler equation has a property of local uniqueness, then the lack of smoothness that is typical in paste connections results in strict inequalities. These are essential to obtain contradictions. An example of a sufficient condition for local uniqueness is

$$\frac{d^2}{dw^2} \ell(\cdot, \cdot, w) \geq \varepsilon > 0.$$

Turning to the value of the Hamiltonian, for Hamiltonian systems that are related to a variational (Lagrangian) principle, as is the case for the combination of (1), (8) and (10), the Hamiltonian is the derivative of the Lagrangian with respect to length scale changes, as illustrated by (13). The fact that H , or equivalently the derivative in (13), is translation-independent (independent of the choice of stretched section²) is a consequence of the Hamiltonian structure for Hamiltonian systems; however, this property can also be derived directly from minimization, since differences in this derivative along the length of the solution would allow for a rescaling and accompanying decrease in L that contradicts c -optimality. The Hamiltonian structure is not necessary

² The term $[u''u']_0^T$ in (13) is considered a perturbation, for large T , in comparison to the term TH .

for the formulation of this property of conservation, nor is it necessary for its proof.

The fact that this constant derivative is zero results from a different argument: if the derivative is non-zero, then by stretching a long section, arbitrarily large changes in L can be made. It remains to make a connection between the ends of the stretched section and the original function u with a penalty that is sufficiently bounded. The possibility of such a connection (which is given by lemma 9 in the case discussed above) does not depend in any important way on the form of the integrand.

In summary, the essence of the arguments that lead to theorems 11 and 10 remains valid for functionals of the more general form (8), under reasonable assumptions on the function ℓ .

References

- [1] Kalies W D and Van der Vorst R C A M 1996 Multitransition homoclinic and heteroclinic solutions of the extended Fisher–Kolmogorov equation *J. Diff. Eq.* **131** 209–28
- [2] Kalies W D, Kwapisz J and Van der Vorst R C A M 1998 Homotopy classes for stable connections between Hamiltonian saddle-focus equilibria *Commun. Math. Phys.* **193** 337–71
- [3] Van den Berg G J B and Van der Vorst R C A M 1999 Second order Lagrangian twist systems: simple closed characteristics *Technical Report* University of Leiden
- [4] Sandstede B 1997 Instability of localized buckling modes in a one-dimensional strut model *Phil. Trans. R. Soc. A* **355** 2083–97
- [5] Champneys A R 1998 Homoclinic orbits in reversible systems and their applications in mechanics, fluids and optics *Physica D* **112** 158–86
- [6] Kalies W, Kwapisz J, Van den Berg J B and Van der Vorst R C A M 2000 Homotopy classes for stable periodic and chaotic patterns in fourth order Hamiltonian systems *Commun. Math. Phys.* **214** 573–92
- [7] Hobbs R E 1981 Pipeline buckling caused by axial loads *J. Construct. Steel Res.* **1** 2–10
- [8] Hobbs R E 1984 In-service buckling of heated pipelines *ASCE J. Transp. Eng.* **110** 175–89
- [9] Hunt G W and Blackmore A 1997 Homoclinic and heteroclinic solutions of upheaval buckling *Phil. Trans. R. Soc. A* **355** 2185–95
- [10] Lazer A C and McKenna P J 1990 Large-amplitude periodic oscillations in suspension bridges: some new connections with nonlinear analysis *SIAM Rev.* **32** 537–78
- [11] Hunt G W and Ahmer Wadee M 1998 Localization and mode interaction in sandwich structures *Proc. R. Soc. A* **454** 1197–216
- [12] Ahmer Wadee M and Hunt G W 1998 Interactively induced localized buckling in sandwich structures with core orthotropy *Trans. ASME J. Appl. Mech.* **65** 523–8
- [13] Budd C J and Peletier M A 2000 Approximate self-similarity in models of geological folding *SIAM J. Appl. Math.* **60** 990–1016
- [14] Peletier M A 2001 Sequential buckling: a variational analysis *SIAM J. Math. Anal.* **32** 1142–68
- [15] Peletier L A and Troy W C 1998 Multibump periodic travelling waves in suspension bridges *Proc. R. Soc. Edin.* **128** A 631–59
- [16] Hunt G W, Peletier M A, Champneys A R, Woods P D, Ahmer Wadee M, Budd C J and Lord G L 2000 Cellular buckling in long structures *Nonlinear Dynam.* **21** 3–29
- [17] Leizarowitz A and Mizel V J 1989 One dimensional infinite-horizon variational problems arising in continuum mechanics *Arch. Ration. Mech. Anal.* **106** 161–94
- [18] Coleman B D, Marcus M and Mizel V J 1992 On the thermodynamics of periodic phases *Arch. Ration. Mech. Anal.* **117** 321–47
- [19] Marcus M 1993 Uniform estimates for a variational problem with small parameters *Arch. Ration. Mech. Anal.* **124** 67–98
- [20] Zaslavski A J 1995 The existence of periodic minimal energy configurations for one-dimensional infinite horizon variational problems arising in continuum mechanics *J. Math. Anal. Appl.* **194** 459–76
- [21] Zaslavski A J 1995 The existence and structure of extremals for a class of second order infinite horizon variational problems *J. Math. Anal. Appl.* **194** 660–96

-
- [22] Zaslavski A J 1996 Structure of extremals for one-dimensional variational problems arising in continuum mechanics *J. Math. Anal. Appl.* **198** 893–932
 - [23] Mizel V J, Peletier L A and Troy W C 1998 Periodic phases in second-order materials *Arch. Ration. Mech. Anal.* **145** 343–82
 - [24] Marcus M 1998 Universal properties of stable states of a free energy model with small parameters *Calc. Var. Partial Diff. Eq.* **6** 123–42
 - [25] Marcus M and Zaslavski A J 1999 The structure of extremals of a class of second order variational problems *Ann. Inst. H Poincaré Anal. Non Linéaire* **16** 593–629
 - [26] Marcus M and Zaslavski A J 1999 On a class of second order variational problems with constraints *Israel J. Math* **11** 1–28
 - [27] Coleman B D 1983 Necking and drawing in polymeric fibers under tension *Arch. Ration. Mech. Anal.* **83** 115–37